



**Electronic Brake Controller  
Hayes Brake Controller Company P/N 81770**

**INSTALLATION MANUAL**

**For trailers with 2-8 electric brakes and vehicles with 12 volt negative ground systems only.**

**READ AND SAVE THESE INSTRUCTIONS**

- Before beginning installation, read and become familiar with these instructions.
- Leave in tow vehicle for future reference.
- **IMPROPER INSTALLATION AND OPERATION COULD CAUSE PERSONAL INJURY AND/OR EQUIPMENT AND PROPERTY DAMAGE.**
- Questions on installation, adjustment, trouble shooting, or operation of brake controllers
- Call **800-892-2676** Monday through Friday between 8:00 a.m. and 5 p.m. Eastern Time.

**SAFETY INFORMATION**



**WARNING:** Indicates a potentially hazardous situation that, if not avoided, could result in death or serious, personal injury.



**CAUTION:** Indicates a potentially hazardous situation that, if not avoided, could result in damage to product or property.



**TIP:** Contains helpful information to facilitate installation.

## Installation



### CAUTION:

- In the automatic mode and minimum power setting at 10, noticeable braking is applied only when the sensor detects deceleration.
- With the vehicle at rest and the brake pedal depressed, there should be only a slight output to the trailer brakes (when minimum power is set to 10).
- Higher at rest outputs and reverse braking can be obtained by increasing the minimum power setting.

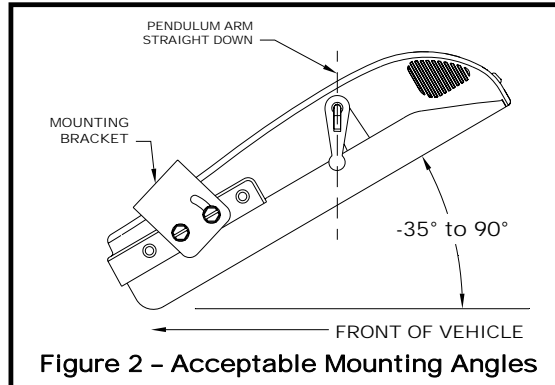
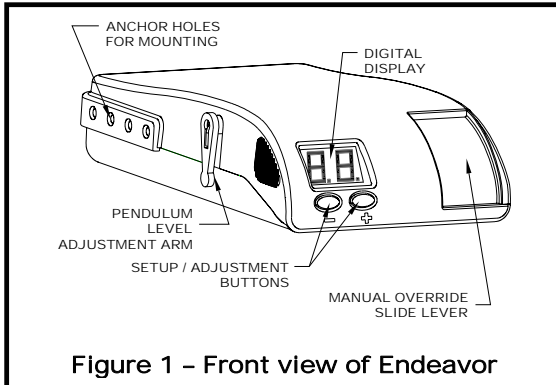

### **Mounting Angle**

Mounting angles between -35 and + 90 degrees can be accommodated by the controller. **THE UNIT MUST, HOWEVER, BE INSTALLED SO THAT IT IS PARALLEL WITH THE TRAVEL OF THE TOW VEHICLE AND TRAILER.**

## Controller Mounting & Installation

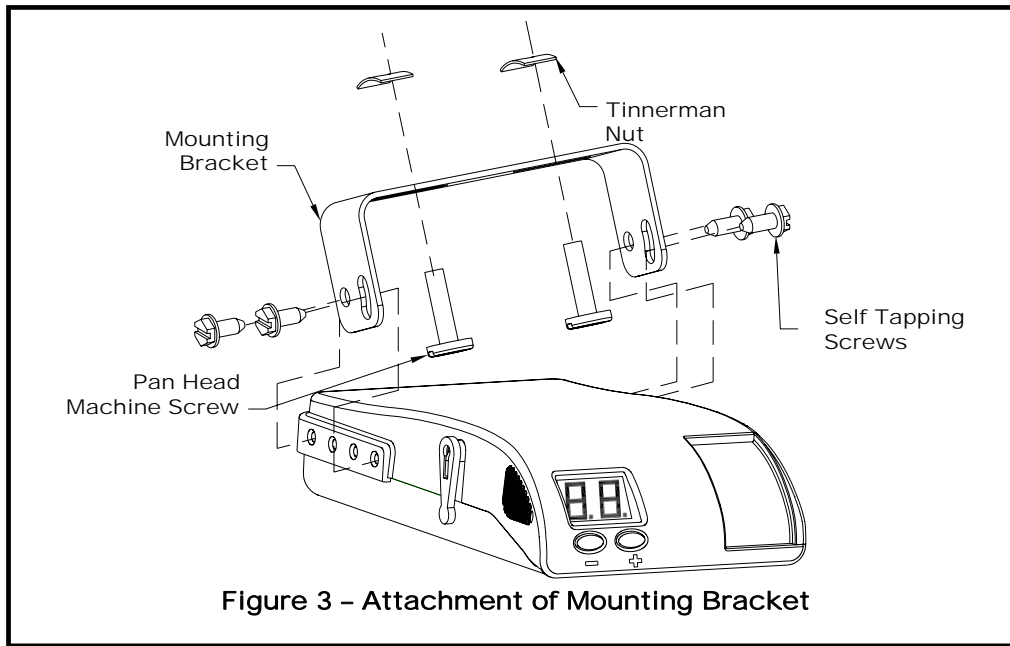

### Controller and Bracket Mounting

- The bracket provided is to be used for mounting the controller to the tow vehicle.
- Use the reversible slotted bracket.
- **DO NOT MOUNT CONTROLLER UPSIDE DOWN OR SIDWAYS.**



#### **WARNING:**

- If the controller is mounted incorrectly, the pendulum cannot operate correctly and may cause loss of braking.

Formatted: Font: (Default) Arial

## Installation Steps

1. Install the mounting bracket to a solid surface under the tow vehicle dash using the two machine screws and fasteners provided. Tighten until snug. **See Figure 3 – Attachment of Mounting Bracket.**
2. Insert four of the self tapping screws provided through the mounting bracket holes and into the desired controller anchor holes. Tighten until snug.
3. **Mount in a location which allows the driver to easily apply the manual override slide lever and see the digital display.**



### WARNING:

- Use of longer screws than those provided can damage the unit and cause loss of braking.

Formatted: Font: (Default) Arial



### WARNING:

- All four controller wires must be connected properly for the controller to operate correctly.
- Failure to properly connect all four wires can cause loss of trailer braking.
- Improper wiring will destroy the controller and void the manufacturer's warranty.



### CAUTION:

- Care must be taken to ensure that the mounting surface is rigid enough to prevent excessive vibration.
- Excessive vibration may result in poor performance.

Formatted: Font: (Default) Arial

Read ALL wiring instructions prior to making electrical connections to the tow vehicle.



**WARNING:**

**To reduce the risk of injury or damage to property:**

- Always connect the **white wire first** and the **black wire second**.
- All four controller wires must be connected properly for the controller to operate correctly.
- Failure to connect the wires correctly can cause loss of trailer braking.



**WARNING:**

- The white wire must be connected to a known good ground (preferably the negative battery post).
- Improper or no ground will result in poor controller performance or lack of performance altogether.
- Improper ground connection can destroy the controller and void the manufacturer's warranty.



**WARNING:**

- Improper connections may result in no trailer brakes or destroy the controller and void the manufacturer's warranty.
- Refer to the vehicle manufacturer or to Hayes Lemmerz (800-892-2676) for the latest controller red stoplight wire to stop lamp switch connections.



**WARNING:**

**Follow wiring instructions.**

- Improper wiring will destroy the controller and void the manufacturer's warranty.



**CAUTION:**

- **DO NOT** connect the black wire to any vehicle power supply line or fuse panel that could cause circuit overload or damage to tow vehicle wiring and vehicle electronics.
- Route the black wire through a grommet hole in the fire wall to prevent wire grounding and away from the radio antenna to reduce any possible AM radio interference.

## Controller Wiring Instructions



### TIP:

- Special Dual-Mated "Quik Connect™" Wiring Harnesses are available for all Hayes Brake Controllers fitted with a connector on the wire leads, making connection a snap. Harnesses are available through all dealer resources. Ask specifically for the Hayes Brake Controller Company (HBC) brand harnesses to match your controller.

The following chart describes the function of each of the controller's wires:

Order	Color	Function	Wire Size (AWG)	Connect To
1 <sup>st</sup>	White	Ground	16	grounded metal part of the firewall or directly to the negative (-) terminal of the battery. <b>Connect this wire first.</b>
2 <sup>nd</sup>	Black	+ connection to the vehicle's power system	12	positive (+) terminal of the battery. <b>MUST</b> have a self-resetting Circuit Breaker in-line between the controller and the battery. See chart for proper size. Route the black wire through a grommet hole in the fire wall to prevent wire grounding and away from the radio antenna to reduce any possible AM radio interference. <b>Connect this wire second.</b>
3 <sup>rd</sup>	Red	Stoplight	14	non-powered stop lamp wire (of the stop lamp switch) or trailer tow wiring harness. It is recommended that a 20-amp inline fuse be installed between the controller's red wire and the stop lamp switch. <b><u>The fuse is required in 1999 &amp; later Fords.</u></b>
4 <sup>th</sup>	Blue	Output to trailer brakes	12	the trailer brake wire or tow vehicle / trailer connector.

**IMPORTANT:** Make all controller wiring connections to the wiring harness before connecting the harness to the vehicle.

### SELF-RESETTING CIRCUIT BREAKER SIZE CHART

Number of Brake Light Bulbs (tow vehicle Plus trailer)	Number of Trailer Brakes			
	2 Brakes	4 Brakes	6 Brakes	8 Brakes
4 Bulbs (minimum)	20 AMP	30 AMP	30 AMP	40 AMP
5 Bulbs	20 AMP	30 AMP	30 AMP	40 AMP
6 Bulbs	20 AMP	30 AMP	40 AMP	40 AMP
7 Bulbs	30 AMP	30 AMP	40 AMP	40 AMP
8 Bulbs	30 AMP	30 AMP	40 AMP	50 AMP
9 Bulbs	30 AMP	40 AMP	40 AMP	50 AMP

**Note:** Each trailer brake magnet is assumed to draw 3 amps of current and each brake lamp bulb is assumed to draw 2 amps.

## Special Conditions

For tow vehicles equipped with factory trailer towing package;

- Refer to your vehicle's owner's manual or other information provided by the manufacturer in determining the correct connection points for the controller.
- See Appendix section for partial list of manufacturer wiring harness to controller conversions.

For vehicles without a trailer-towing package: refer to the wiring diagram in Figure 4.

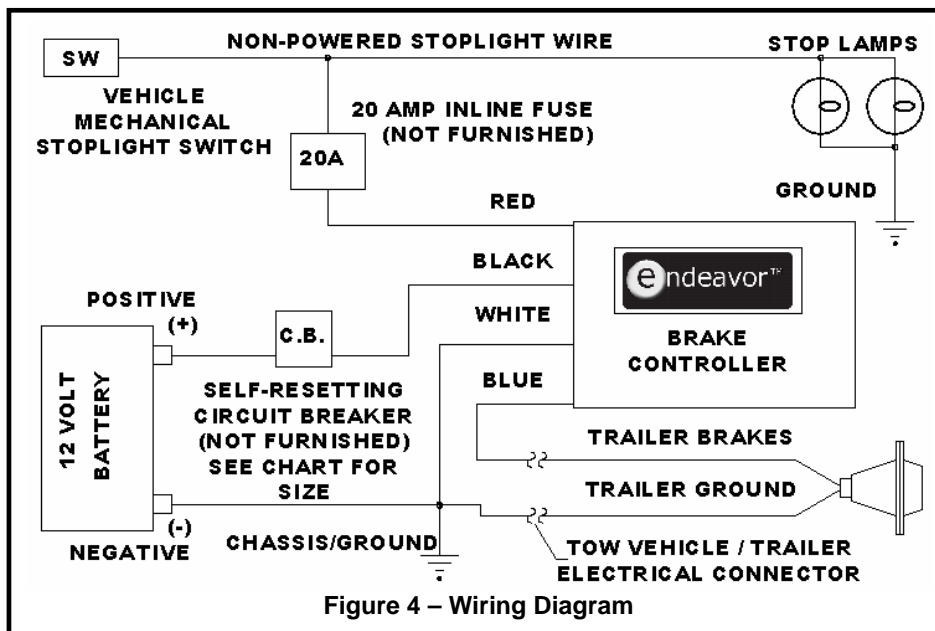

### WARNING:

**1989-1991 Ford Bronco, Econoline, F-Superduty, and F150-350 Series:**

- The red stoplight wire **MUST** splice into the turn signal connector harness and **NOT** to the stoplight switch.
- Connecting to the terminal of the stoplight switch will break the switch and result in no stoplights and no trailer braking.



### WARNING:

**All 1999 and later Ford vehicles without the trailer wiring package:**

- The red controller wire must be connected to the light green wire of the brake stop lamp through a 20-amp inline fuse.
- Failure to install a 20-amp inline fuse can destroy the controller and void the manufacturing warranty.

## OEM TOW VEHICLE WIRING CONVERSION

<u>CHRYSLER (THROUGH 2002)</u>		<u>CONTROLLER</u>	<u>FUNCTION</u>	<u>CHRYSLER (NEW)</u>
<u>RED W/BLACK TRACE</u>	<u>BLACK</u>	<u>+12 VOLT SUPPLY</u>	<u>WHITE WITH RED TRACE</u>	
<u>WHITE W/TAN TRACE</u>	<u>RED</u>	<u>STOPLIGHT</u>	<u>BLUE WITH WHITE TRACE</u>	
<u>BLUE</u>	<u>BLUE</u>	<u>TRAILER BRAKES</u>	<u>BLUE</u>	
<u>BLACK</u>	<u>WHITE</u>	<u>GROUND</u>	<u>GREEN WITH BLACK TRACE</u>	

<u>FORD (THROUGH 2002)</u>		<u>CONTROLLER</u>	<u>FUNCTION</u>	<u>FORD (NEW)</u>
<u>RED</u>	<u>BLACK</u>	<u>+12 VOLT SUPPLY</u>	<u>PINK</u>	
<u>LIGHT GREEN</u>	<u>RED</u>	<u>STOPLIGHT</u>	<u>RED</u>	
<u>BLUE</u>	<u>BLUE</u>	<u>TRAILER BRAKES</u>	<u>BLUE</u>	
<u>WHITE</u>	<u>WHITE</u>	<u>GROUND</u>	<u>WHITE</u>	
<u>BROWN</u>	<u>NOT USED</u>	<u>ILLUMINATION</u>	<u>BROWN</u>	

<u>FORD EXPEDITION</u>		<u>CONTROLLER</u>	<u>FUNCTION</u>
<u>RED</u>	<u>BLACK</u>	<u>+12 VOLT SUPPLY</u>	
<u>RED/GREEN TRACE</u>	<u>RED</u>	<u>STOPLIGHT</u>	
<u>BLUE</u>	<u>BLUE</u>	<u>TRAILER BRAKES</u>	
<u>BLACK</u>	<u>WHITE</u>	<u>GROUND</u>	

<u>GENERAL MOTORS</u>		<u>CONTROLLER</u>	<u>FUNCTION</u>
<u>RED</u>	<u>BLACK</u>	<u>+12 VOLT SUPPLY</u>	
<u>LIGHT BLUE</u>	<u>RED</u>	<u>STOPLIGHT</u>	
<u>DARK BLUE</u>	<u>BLUE</u>	<u>TRAILER BRAKES</u>	
<u>BLACK</u>	<u>WHITE</u>	<u>GROUND</u>	
<u>BROWN</u>	<u>NOT USED</u>	<u>ILLUMINATION</u>	

<u>2004 INFINITY</u>		<u>CONTROLLER</u>	<u>FUNCTION</u>
<u>RED</u>	<u>BLACK</u>	<u>+12 VOLT SUPPLY</u>	
<u>RED/GREEN</u>	<u>RED</u>	<u>STOPLIGHT</u>	
<u>BROWN/WHITE</u>	<u>BLUE</u>	<u>TRAILER BRAKES</u>	
<u>BLACK</u>	<u>WHITE</u>	<u>GROUND</u>	
<u>RED/BLUE</u>	<u>NOT USED</u>	<u>ILLUMINATION</u>	

<u>RANGE ROVER</u>		<u>CONTROLLER</u>	<u>FUNCTION</u>
<u>REMOVE TAIL LIGHT &amp; CONNECT RED</u>	<u>BLACK</u>	<u>+12 VOLT SUPPLY</u>	
<u>CONTROLLER WIRE TO</u>	<u>RED</u>	<u>STOPLIGHT</u>	
<u>BLACK/BLUE TRACE, NO</u>	<u>BLUE</u>	<u>TRAILER BRAKES</u>	
<u>LIGHT WITH MANUAL</u>	<u>WHITE</u>	<u>GROUND</u>	
	<u>NOT USED</u>	<u>ILLUMINATION</u>	

<u>2004 TITAN/ARMADA</u>		<u>CONTROLLER</u>	<u>FUNCTION</u>
<u>RED</u>	<u>BLACK</u>	<u>+12 VOLT SUPPLY</u>	
<u>RED/GREEN</u>	<u>RED</u>	<u>STOPLIGHT</u>	
<u>BROWN/WHITE</u>	<u>BLUE</u>	<u>TRAILER BRAKES</u>	
<u>BLACK</u>	<u>WHITE</u>	<u>GROUND</u>	
<u>RED/BLUE</u>	<u>NOT USED</u>	<u>ILLUMINATION</u>	

<u>2004 TOYOTA TUNDRA</u>		<u>CONTROLLER</u>	<u>FUNCTION</u>
<u>BLACK-RED</u>	<u>BLACK</u>	<u>+12 VOLT SUPPLY</u>	
<u>GREEN-WHITE</u>	<u>RED</u>	<u>STOPLIGHT</u>	
<u>RED</u>	<u>BLUE</u>	<u>TRAILER BRAKES</u>	
<u>BROWN</u>	<u>WHITE</u>	<u>GROUND</u>	